

## Seasonal variation of the atmospheric energy budget on Mars

F. Tabataba-Vakili (1), P.L. Read (1), S. R. Lewis(2), L. Montabone(3,4), T. Ruan (1), A. Valeanu (1), Y. Wang (1), R.M.B. Young(1)

(1) Atmospheric Oceanic and Planetary Physics, University of Oxford, Oxford, UK (tabataba-vakili@atm.ox.ac.uk), (2) Department of Physical Sciences, The Open University, Milton Keynes, UK, (3) Université Pierre et Marie Curie, Laboratoire de Météorologie Dynamique, Paris, France, (4) Space Sciences Institute, Boulder, CO, USA.

### Abstract

We compute a detailed Lorenz energy budget [1] to improve our understanding of the dynamical circulation of the martian atmosphere. Results suggest that the circulation of the martian atmosphere is governed mostly by baroclinic instability, except during a 2 to 3 month long period around the northern hemisphere winter solstice when barotropic and baroclinic instabilities coincide. The difference between diurnally averaged quantities and the full energy budget also indicate a major role for diurnal tides in enabling a direct transfer of energy from diurnal heating to eddy potential and kinetic energy.

### 1. Introduction

Planetary atmospheric circulation is largely driven by the distribution of incoming solar radiation. The resulting differential heating of the atmosphere increases its potential energy, which is converted into circulatory kinetic energy through dynamical processes. To understand this conversion of energy we use the framework of the Lorenz energy budget [1]. Here the energy of the atmosphere is separated into zonal and eddy components of the kinetic and the available potential energy to calculate conversion terms between the energy components.

Such studies have been performed extensively for Earth, but until recently this approach had not been extensively used in a systematic way to study other Solar System planets. In this study we provide a detailed energy budget of the martian atmosphere from martian year (MY) 24 to 27.

### 2. Data sources

For our study on the mechanical energy budget of Mars we use data from the UK Mars reanalysis dataset MACDA [2] based on the UK version of the LMD-UK

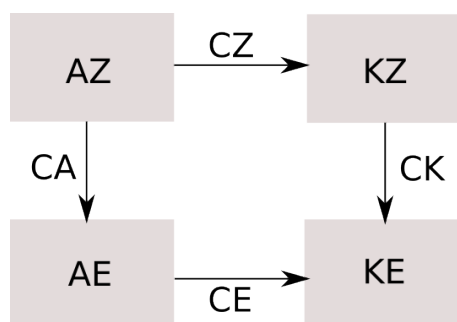

Figure 1: Box diagram of Lorenz energy budget. The depicted energies are the zonal available potential (AZ), eddy available potential (AE), zonal kinetic (KZ), and eddy kinetic (KE) energy, respectively. The conversion terms CA, CE, CK, and CZ are directed as depicted.

Mars GCM [3], thereby covering complete diurnal cycles of the martian atmosphere from 141 degrees solar longitude in MY 24 through 82 degrees solar longitude in MY 27.

### 3. Mechanical energy budget

We compute the mechanical energy budget for every 30 sols using energy equations provided [4], which provide an exact approach to addressing the planet's topography in isobaric coordinates. We compute a reference atmosphere using a terrain-dependent, iterative approach [5] to derive the available potential energy. A daily running mean is applied to the data to filter out diurnal effects.

Figure 2 shows energy and conversion terms for three martian years. For some energy terms yearly recurring values can be observed. The conversion terms do not seem to follow any periodical recurrence. For KE, CE and CZ a sharp peak is observed in early northern hemisphere autumn of MY 25 (MY 25.5). This feature coincides with the planet encircling dust

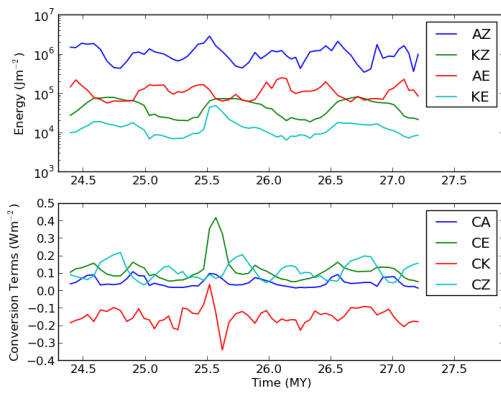

Figure 2: Energy and conversion terms during MY 24 - MY 27

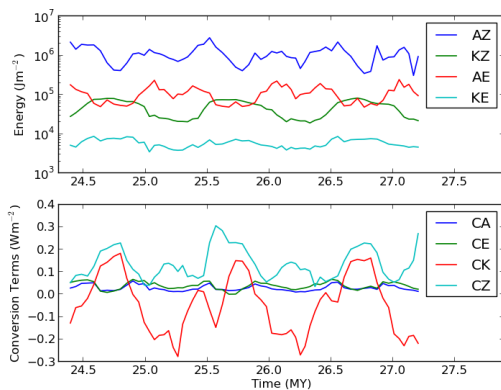

Figure 3: Daily-averaged energy and conversion terms during MY 24 - MY 27

storm of MY 25.

When applying a daily running mean to all input data, we obtain periodic conversion terms with a period of one MY (see Fig. 3). The effects of the dust storm of MY 25 become greatly weakened in the daily-averaged case, which shows that a large part of the effect of the storm is on the tides.

An important result of our study is the seasonal periodicity and the behavior of the conversion terms. During the whole year CA and CE in Fig. 3 are positive, which suggests baroclinic instability. CK, on the other hand, changes its sign periodically. Since a positive CK indicates barotropic exchanges in the atmosphere, each martian year there is a time period of 2 to 3 months around the northern hemisphere winter solstice when the circulation of the martian atmosphere

is influenced by both barotropic and baroclinic instabilities. This suggests a greater role for mixed baroclinic/barotropic instability than is typical for Earth.

## References

- [1] Lorenz, E. N.: Available potential energy and the maintenance of the general circulation, *Tellus*, 7.2, pp. 157-167, 1955.
- [2] Montabone, L., Lewis, S. R., Read, P. L.: Mars Analysis Correction Data Assimilation (MACDA): MGS/TESv1.0, [Internet]. NCAS British Atmospheric Data Centre, 29 November 2011, doi:10.5285/78114093-E2BD-4601-8AE5-3551E62AEF2B, 2011.
- [3] Forget, F., Hourdin, F., Fournier, R., Hourdin, C., Talagrand, O., Collins, M., Lewis, S.R., Read, P.L. and Huot, J.-P.: Improved general circulation models of the Martian atmosphere from the surface to above 80 km, *J. Geophys. Res.* Vol. 104 (E10), 24155-24176, 1999.
- [4] Boer, G. J.: On exact and approximate energy equations in pressure coordinates, *Tellus A*, 41.2, pp. 97-108, 1989.
- [5] Koehler, T. L.: A terrain dependent reference atmosphere determination method for available potential energy calculations, *Tellus A*, 38.1, pp. 42-48, 1986.